

Owners Manual

Öhlins motocross front forks TM



Including:

Setting up
your bike

Fine-tuning

Service
the fork

General
handling set-up

Technical info

Spare parts



Safety signals

Important information concerning safety is distinguished in this manual by the following notations:



*The Safety alert symbol means:
Caution! Your safety is involved.*

⚠ WARNING!

*Failure to follow warning instructions could result in **severe or fatal injury** to anyone working with, inspecting or using the suspension, or to bystanders.*

CAUTION!

Caution indicates that special precautions must be taken to avoid damage to the suspension.

NOTE!

This indicates information that is of importance with regard to procedures.

Introduction

All of Öhlins advanced suspension products are adapted to the brand and model. This means that length, travel, spring, action and damping characteristics, are tested individually just for your motorcycle.

Before installation

Öhlins Racing AB can not be held responsible for any damage whatsoever to front fork or vehicle, or injury to persons, if the instructions for fitting and maintenance are not followed exactly.

Similarly, the warranty will become null and void if the instructions are not adhered to.

Contents

Safety signals	2
Introduction	2
Before installation	2
Tuning the suspension	3
Design	3
Settings	4
Setting the spring preload	4
Fine tuning the bike	5
Preload adjustment	7
Changing springs	9
Technical information	10
Spare parts	11
General handling set-up	14
Maintenance	15

NOTE

Öhlins products are subject to continual improvement and development. Consequently, although these instructions include the most up-to-date information available at the time of printing, there may be minor differences between your suspension and this manual. Please consult your Öhlins dealer if you have any questions with regard to the contents of the manual.

© Öhlins Racing AB.

All rights reserved.

Any reprinting or unauthorized use without the written permission of Öhlins Racing AB is prohibited.

Printed in Sweden.

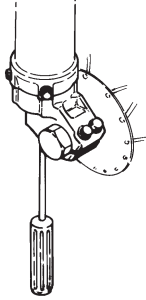

1.
The compression adjuster is located at the bottom of the fork leg.

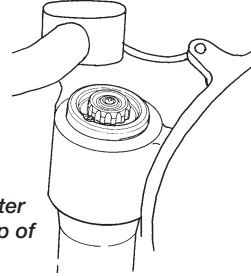

2.
The rebound adjuster is located at the top of the fork leg.

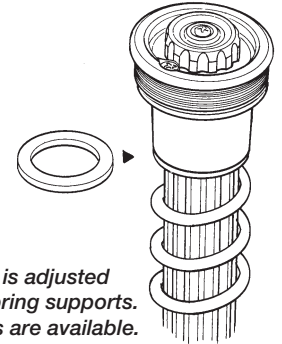

3.
Spring pre-load is adjusted with different spring supports. Optional springs are available.

Tuning the suspension

Motorcycle road holding qualities

All motorcycles are designed with a suspension geometry that includes height and fork angle. The changing of components can affect this and it is therefore essential that both the rear and the front ends match each other.

Changing to Öhlins suspension gives optimum performance only when both the front fork and the rear suspension interact properly. It is of the greatest importance that the front and rear loaded heights are within the specified values.

In the Mounting Instructions, see section: *Setting the spring pre-load.*

Design

Öhlins new upside-down (USD) front fork is designed to combine the advantages of comfortable, safe conventional forks and rigid, light USD forks. The result is a unique combination of being rigid, precise in corners and during hard braking yet comfortable, forgiving during “over-landing” and in big bumps.

Your new Öhlins USD front fork has aluminium outer legs and 46 mm steel inner legs, with a polished surface for lowest possible friction.

The new USD fork features the Öhlins cartridge damping system.

The fork is fully adjustable with external adjuster for compression and rebound damping.

The compression adjuster is located at the bottom of the fork leg (Fig.1), the rebound adjuster at the top (Fig.2).

Spring pre-load is adjusted with spring supports of different heights (Fig.3), and optional springs are available to suit different tracks and riders.

In the legs there are also “air-springs“ (the air trapped above the oil) that work together with the “real“ spring. You adjust the air-spring by raising or lowering the oil level in the legs.

By using different combinations of springs and air-springs you can alter the characteristic of the fork. For example, a soft spring in combination with a small air-spring (high oil level) makes the fork progressive; see *Fine-tuning the bike.*

Marking

All Öhlins front forks are marked. You will find the part number on the inside of the fork bottom.

Recommended settings

The front fork in your kit is adjusted to the Öhlins recommended setting for your bike. We advise you to use this as your start setting.

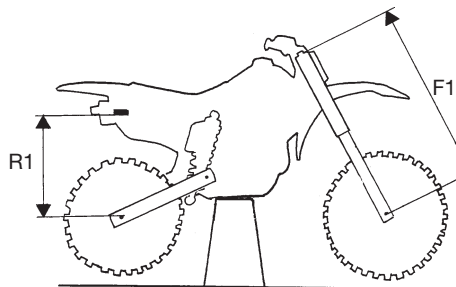

Bike on a stand.

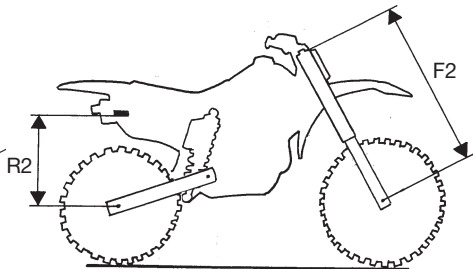

Bike on the ground.

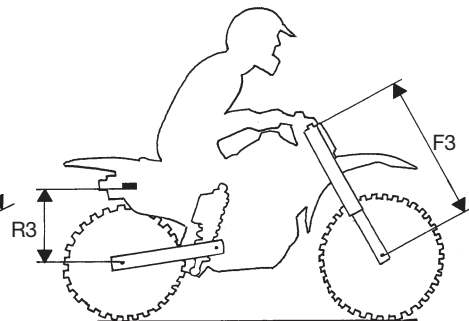

Bike with rider on.

Settings

Basic settings

Always ensure that the basic setting made by Öhlins is correct. It is adapted to the make and model (in its original state) and for a rider of average weight.



WARNING

Incorrect spring action can produce a fork angle that is too steep or too flat. This in turn will give a tendency for oversteering or understeering, which could seriously affect the handling characteristics of the motorcycle.

The original setting of the front fork, when delivered from Öhlins, should always be a base when the settings are changed by use of the adjustment devices.

Setting the spring pre-load

Measuring

Pre-load on the spring/springs is very important, because it affects the height of the motorcycle and the fork angle. Consequently, handling characteristics can be changed, even negatively. Proceed as follows (it will be much easier if done by two persons):

- Place the motorcycle on a stand, so the front fork and the rear end are in fully extended position.
- Measure the distance, eg. from the lower edge of the rear mudguard or from a point marked by a piece of tape, immediately above the rear wheel axle, to the wheel axle (R1).
- Make a similar measurement on the front axle, e.g. from the bottom of the upper fork crown to the front wheel axle (F1).

- Allow the motorcycle (without rider) to apply load on the springs and repeat the measuring procedure (R2, F2).
- Then take the same measurements with the rider and equipment on the motorcycle (R3, F3). It is important that the rider has a correct riding posture, so that the weight is balanced on the front and rear wheel in the same way as when riding.

Recommendations

The difference should not deviate from the following sizes, if no other recommended settings are given in the Mounting Instructions:

Free sag: (R1-R2), (F1-F2)

Rear: MX/Off-Road 30±5 mm

Front: MX/Off-Road 30±5 mm

Ride height: (R1-R3), (F1-F3)

Rear: MX 100±5 mm

Off Road 30% of the total stroke

Front: MX/Off-Road 80±5 mm

Compression stroke

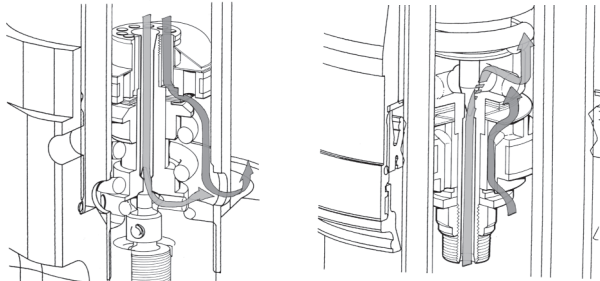

Flow in compression valve

Flow in rebound valve

Rebound stroke

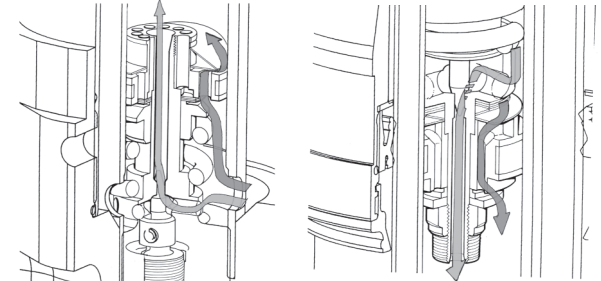

Flow in compression valve

Flow in rebound valve

Fine-tuning the bike

Learning how to use the adjusters will take time but you quickly appreciate them once you know the tricks. Even the specialists sometimes need a specialist!

With the adjusters you optimize the suspension for your riding style and the track you are competing on.

The same basic guidelines go for both the front fork and the rear shock absorber.

Too much compression damping will give you a harsh ride as your bike “jumps” along the track.

With too much rebound damping your bike will have difficulties with several bumps in a row. The suspension will not extend fast enough between bumps, your bike will ride lower and lower and eventually the suspension will bottom!

External adjusters

On the Öhlins front fork the adjusters are bleed valves, completely separated from each other.

The compression bleed valve controls the flow

in the cartridge tube during the compression stroke, the rebound bleed valve controls the flow during the rebound stroke.

CAUTION!

Using too much force when closing the adjusters will destroy important sealing surfaces.

Both the adjusters have a normal right-hand thread.

Click position zero (0) is when the adjusters are turned clockwise to fully closed.

The adjustment range, from fully closed until maximum open valve (anticlockwise), is 20 clicks. In order not to click in the wrong direction; always first close the adjuster, then dial-in the new setting.

Making adjustments

To make improvements using the adjusters, it is important to understand the function of the front fork and the shock absorber and through testing learn how they effect the handling of your bike.

Make sure that you have the correct springs and the correct spring pre-load before making any adjustments. And always start with the Öhlins recommended settings.

NOTE!

See Mounting Instructions for recommended settings.

NOTE!

Higher click numbers give less damping force.

When making adjustments, keep notes, make adjustments one at a time...and in small steps.

The adjusters should normally not be adjusted in steps of more than 2 clicks at a time and not outside the usable click range.

When you think you have made an improvement, go back to what you started with and double check to be sure. Pay attention to changes in conditions like tires, temperatures etc.

Air spring

4.

A change in oil level will effect the damping forces, not in the early stage of fork travel but a great deal in the later stage.

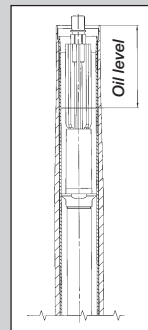
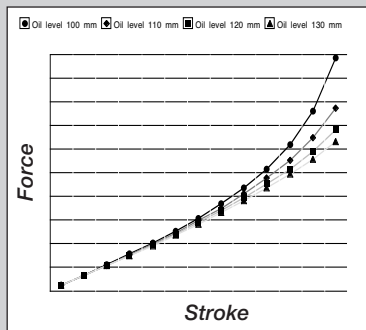

Oil level

5.

Oil level is measured from the top of the outer leg, with the top nut off, the fork fully compressed and no pre-load washer or spring installed.

In general, compression damping changes should be used to influence the bike's stability and response, while rebound damping changes should be used to influence comfort and traction.

When you need more damping force, you should mainly try to increase compression damping and use as little rebound damping as possible.

This usually means that you gain comfort and performance in handling.

Oil level adjustment

As the air trapped between the oil and the top nut acts as an air-spring, a change in oil level will effect the damping forces. Not in the early stage of fork travel, but a great deal in the later stage.

A general description of how the oil level/air-spring effects the damping forces are shown in Fig.4.

The air-spring gives the Öhlins USD fork a progressive spring rate, preventing it from bottoming out hard.

By using different combinations of springs and oil levels/air-springs you can alter the characteristic of the fork and tailor it to suit different tracks and conditions.

CAUTION!

The oil level must be the same in both front fork legs. Riding a bike with different oil levels will cause instability.

When the oil level is raised

The air-spring in the later half of travel is strong, and thus the front fork hard.

When the oil level is lowered

The air-spring in the later half of travel is soft, and thus the front fork soft.

CAUTION!

Adjust the oil level with the fork leg fully compressed and no pre-load washer or spring installed.

NOTE!

See Mounting Instructions for recommended oil level.

The oil level is measured from the top of the outer leg, with the top nut off (Fig.6).

Changes in oil level should be made in small steps. We recommend a change of 5 mm at a time and not outside the range of 80-130 mm.

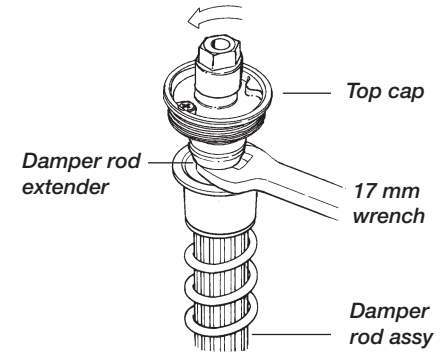
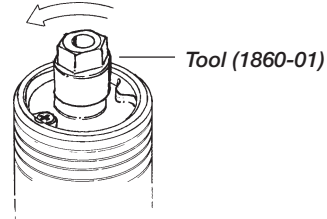
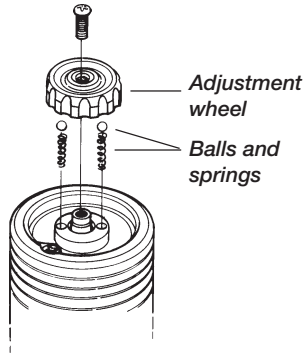

Pre-load adjustment

- 1 Put the bike on a stand and loosen the screws in the top fork crown that hold the fork legs.

NOTE!

On most MX-bikes you have to take off the handle bar before you can unscrew the top cap.

Remove the adjustment wheel and the springs and balls of the adjuster.

- 2 Unscrew the top cap, use tool. (1860-01). Put a box under the front wheel so that the springs are visible.

- 3 Remove the top cap from the damper rod extender. Use a 17mm wrench, and tool (1860-01).

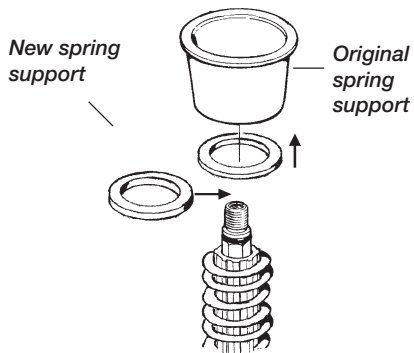

- 4 Remove the original spring support.
Install a new spring support to achieve the right static sag.

- 5 Fit the spring support and the top cap. Tighten the top cap and lock nut to a torque of 20 Nm.

CAUTION!

The piston shaft must bottom in the top cap before the lock nut is tightened.

Refit the adjustment wheel.
Tighten the bolt in the top fork crown to 20 Nm.

NOTE!

The top nut only have to be tightened by hand without extending tool.

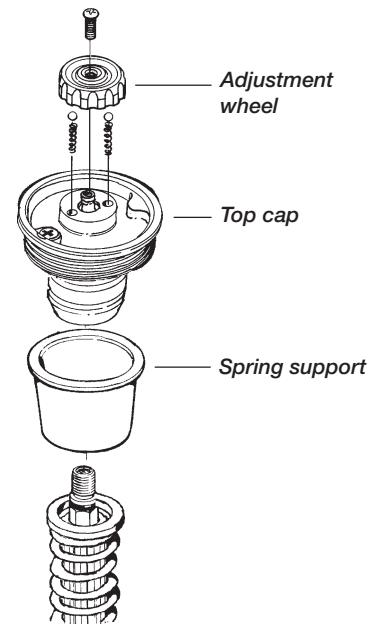

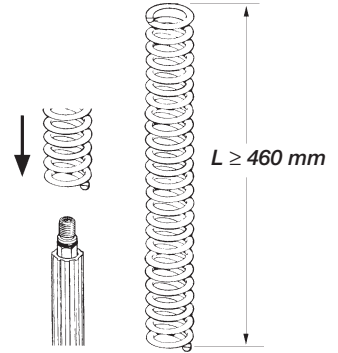
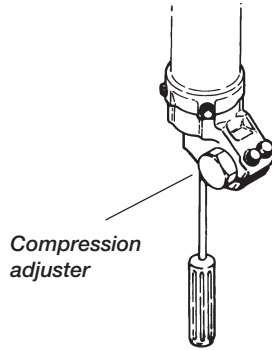
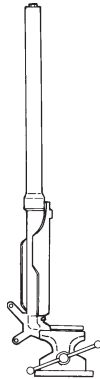

Changing springs

6

Follow instructions 1-4 on previous page and remove the spring. Do not install the spring support spacer.

7

NOTE!

Closing the compression and the rebound valves will keep the damper rod extended making it easier to install the new spring.

Check the oil level according to page 6 and 10.
Pull out the damper rod as far as possible and then close the compression and the rebound valve (clockwise).

8

Install the new spring.

NOTE!

Check the free length of the spring. Original length is 467 mm. If the spring length is under 460 mm the spring must be changed.

Follow instruction 5 on previous page.

Adjust the compression and the rebound valves according to specification card.

Fit the fork legs to the motorcycle
Tightening torques: top fork crown 20 Nm and bottom fork crown 10 Nm.

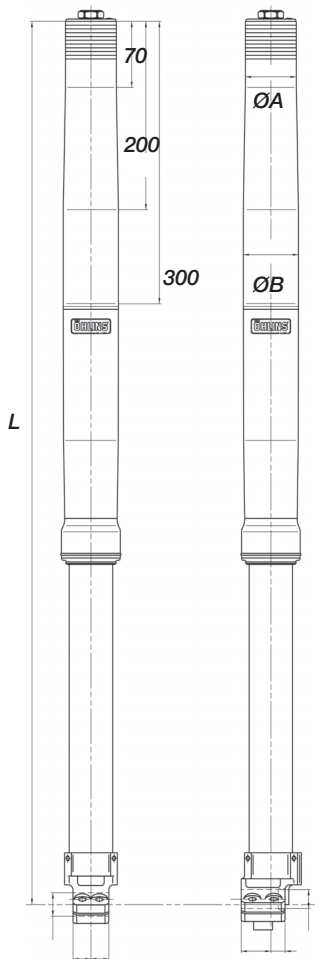

Technical specifications

Fork lengths and diameters

Front fork	Motorcycle	Length (L)
ØA	ØB	
FG 2003	TM	935 mm
52,9 mm	58,4mm	

Rebound and compression adjustment

Refer to mounting instruction for set-up data.
Maximum open rebound and compression valve:
20 clicks.

Free Spring Length:

All forks: 467 mm (service limit 460 mm).

Spring preload:

Maximum allowed adjustment
range 3-13 mm (with washers).

Spring rate:

(depending on models)

2328-39:	3,9 N/mm
2328-41:	4,1 N/mm
2328-43:	4,3 N/mm
2328-45:	4,5 N/mm
2328-47:	4,7 N/mm

Settings:

Compressing adj.	14 clicks
Rebound adj.	14 clicks

Oil level:

When delivered from factory: 115 mm
Adjustment range: 80-130 mm.

CAUTION!

Use only Öhlins high performance front fork fluid No. 5 (1305-01).

Tighten torque:

Fork top crown bolt: 20 Nm
Fork bottom crown bolt: 10 Nm
Compression valve: 65 Nm (Base valve).
Cylinder tube cap (cartridge/tube): 65 Nm
Compression valve, 8 mm nut 8 Nm.
Rebound valve, 8 mm nut 8 Nm.

Grease:

Öhlins Front Fork grease 00146-01
(Red grease).

Service Intervals:

Every 20 hours.

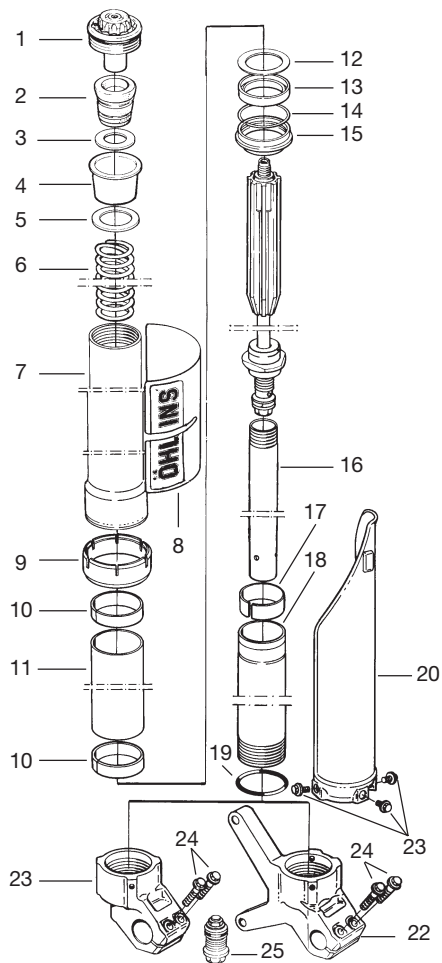

Spare parts

Pos.	Part No.	Pcs.	Description	Type/remarks
1	-	1	Top Cap	
2	02400-01	1	Bump rubber	
3	02403-01	1	Slide washer	
4	02337-01	1	Spring support	
5	02319-01	1	Spring washer	see spec. card
6	02328-39	1	Spring front fork	3,9 N/mm
	02328-41	1		4,1 N/mm
	02328-43	1		4,3 N/mm
	02328-45	1		4,5 N/mm
	02328-47	1		4,7 N/mm
7	02324-02	1	Fork leg outer	
8	02332-05	1	Cover Sticker Öhlins	
9	02409-01	1	Guide sleeve	
10	02021-01	2	Bushing lower	
11	02325-01	1	Sleeve	
12	01552-01	1	Washer	
13	02336-01	1	Seal	
14	02015-01	1	Circlip	
15	02014-01	1	Scraper	
16	02339-01	1	Cylinder tube cartridge	
17	02022-01	1	Bushing upper	
18	02315-83	1	Fork leg inner	
19	00438-30	1	O-ring	
20	02309-80	1	Cover fork leg pair	
21	02314-01	3	Bolt	
22	02396-27	1	Fork bottom left	
23	02396-28	1	Fork bottom right	
24	02314-02	2	Bolt fork bottom	
25	-	1	Base valve assy	
-	00195-01	2	Sticker Öhlins	white / transparent

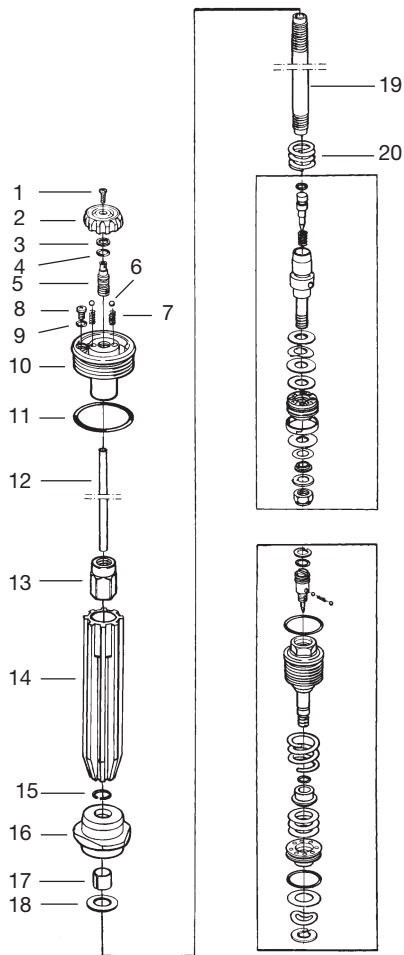

Spare parts

Pos.	Part No.	Pcs.	Description	Type/remarks
1	00828-01	1	Screw	
2	00820-02	1	Adjustment knob	
3	01473-06	1	Circlip	
4	00338-79	1	O-ring	
5	02405-01	1	Adjustment screw	
6	00884-01	2	Ball	
7	00833-01	2	Spring	
8	01050-01	1	Screw	
9	00338-59	1	O-ring	
10	02395-01	1	Top cap	
11		1	O-ring	
12	02366-13	1	Adjustment rod	
13	02402-01	1	Lock nut	
14	02401-01	1	Spring guide	
15	01499-02	1	Circlip	
16	02399-01	1	Cylinder tube cap	
17	00110-01	1	Bushing	
18	02340-01	1	Washer	
19	02393-01	1	Shaft	
20	02063-02	1	Spring	

Tool

1860-01: Top cap releasing tool

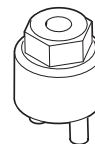

Rebound adjuster

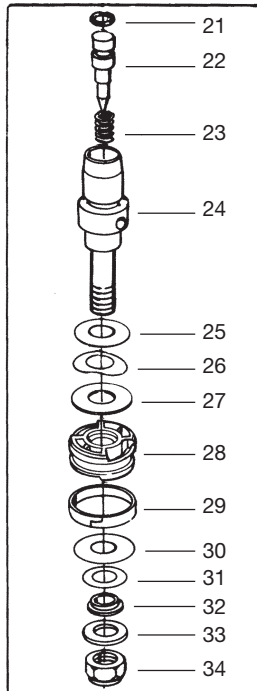

Spare parts

Pos.	Part No.	Pcs.	Description	Type/remarks
21	00438-31	1	O-ring	
22	02356-03	1	Rebound needle	
23	02322-01	1	Spring	
24	02320-03	1	Piston holder	
25	00530-18	1	Shim	see spec. card
26	01149-01	1	Wave washer	see spec. card
27	-	-	Shims	see spec. card
28	02335-01	1	Rebound piston	
29	01447-02	1	Piston ring	
30	-	-	Shim	see spec. card
31	-	-	Shim	see spec. card
32	00641-xx	1	Clamp washer	see spec. card
33	00153-01	1	Washer	
34	00430-05	1	Lock nut	
35	01473-02	1	Circlip	
36	00338-53	1	O-ring	
37	01242-0x	1	Adjustment needle	see spec. card
38	00884-04	2	Ball	
39	01248-01	1	Spring	
40	00438-02	1	O-ring	
41	02413-xx	1	Base valve	see spec. card
42	04107-x0	1	Spring	see spec. card
43	00438-52	1	O-ring	
44	02414-01	1	Poppet valve	
45	-	-	Shim	
46	02415-01	1	Valve seat	
47	00438-03	1	O-ring	
48	00520-23	1	Shim	
49	04105-01	1	Wave washer	
50	05009-12	1	Circlip	

Compression adjuster

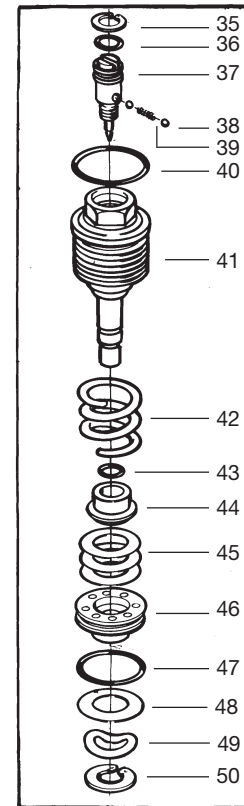

General handling set-up

Front end falls into the curves (oversteering) especially in sand.

Steep front fork angle. Front end too low in comparison to rear end.

- Increase the front fork compression damping.
- Change to harder springs.
- Lower fork leg approximately 5 mm in the triple clamp.

Front end "ploughs", understeers.

Shallow front fork angle. Front end too high in comparison to rear end.

- Decrease the front fork compression damping.
- Raise the fork legs approximately 5 mm in the triple clamp.
- Change to softer fork springs.

Front end unstable at high speed, unstable when accelerating out of curves.

Front fork angle too steep. Front end too low in comparison to rear end.

- Lower the fork legs approximately 5 mm in triple clamp.
- Change the front fork springs to harder ones.

Front end unstable during deceleration.

Front fork angle too steep during braking. Front end too low or rear end too high.

- Increase the oil level in the front fork.
- Change to harder fork springs.
- Increase the front fork compression damping.

Front suspension.

Front fork travel is not used to its full capacity. Harsh feeling, front wheel grip is not satisfactory in bumpy turns.

Suspension too hard.

- Decrease the front fork compression damping.
- Change to softer springs.

Suspension bottoming, too soft during entire travel.

Spring too weak or compression damping too soft.

- Increase oil level 5 mm.
- Increase compression damping.
- Change to stiffer springs.

Suspension bottoming, but can handle smaller bumps.

Damping force not progressive enough.

- Increase the oil level.

Can handle smaller bumps but is too hard during the last part of the travel.

Damping force is too progressive.

- Decrease the oil level.

Front end feels low, initially feels soft, but is not bottoming.

The initial spring rate is too soft or spring preload is too low.

- Increase the spring pre-load.

Feels harsh over small bumps, but using full wheel travel.

Too much spring pre-load or too much compression damping.

- Increase the oil level or change to softer springs.
- Decrease the compression damping.
- Decrease the spring pre-load.
- Clean the oil seals and scrapers. Use Öhlins grease 146-01 for regreasing.

Can handle the first in a series of bumps but feels hard after a few more bumps. Frontal grip insufficient in rough and bumpy turns.

Too much rebound damping.

- Decrease the rebound damping.

Front end rebound too fast after a bump. Front wheel grip insufficient in bumpy curves.

Not enough rebound damping, or too much spring pre-load

- Increase the rebound damping.
- Decrease the spring pre-load.

Maintenance

Telescopic front forks depend on a smooth, friction free action.

Make sure your forks are regularly serviced.

Do not use strong solvents, such as brake cleaner, to clean the front forks. This will dry out the seals and the steel tubes and cause friction or leakage.

After every race

Clean externally and spray with an all-purpose oil after washing with detergent.

Check externally for damage.

Put a little Öhlins red grease (146-01) on the steel tubes and work it in by pushing the fork up and down.

Every 20 hours

Dismantle the fork and check all parts for wear and damage, replace if necessary.

NOTE!

Discarded Öhlins products should be handled over to an authorized work shop or distributor for proper disposal.

More info

www.ohlins.com



Öhlins Racing AB, Box 722, S-194 27 Upplands Väsby, Sweden
Phone +46 8 590 025 00, Fax +46 8 590 025 80

Your Öhlins dealer: